

---

## Magnum Mobile Generator – MMG100 SS Specifications

### ENGINE

- John Deere® PE4045HF285 - turbocharged, diesel engine
  - Prime - 122 hp @ 1800 rpm
  - Standby - 133 hp @ 1800 rpm
  - 4 cylinder
  - 4.5 L displacement
  - Tier III approved
- Steel, single wall fuel tank
  - 147 gal. capacity
  - 22 hr. run time – full load
  - Fuel tank built into skid of generator set
- Fuel consumption at prime:
  - 100% - 6.2 gph (23.5 Lph)
  - 75% - 4.7 gph (17.8 Lph)
  - 50% - 3.1 gph (11.7 Lph)
- Cooling system capable of operating at 120°F ambient
- Low coolant shutdown
- Radiator and oil drains plumbed to exterior
- Rubber vibration dampers isolate engine/generator from frame
- Disposable air filter - paper element
- Air filter restriction indicator mounted on control panel
- 60 Hz engine/generator
- Electronic isochronous governing

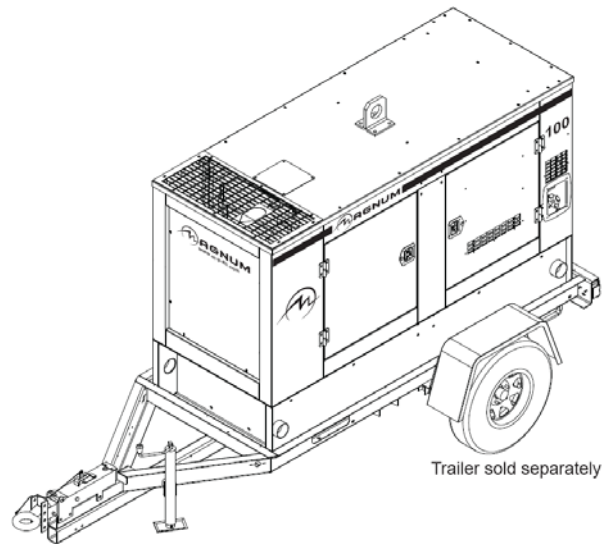

### SUPER START GENERATOR

- Marathon Electric®
  - Brushless
  - 4 pole
  - Class H insulation
- Voltage regulation +/- 1% with Marathon SE350 Voltage Regulator
- Reduces voltage dip on starting events
- Reduces internal operating temperature of the generator
- Increases single motor starting by 89% (compared to standard model)
- 275 kVA (starting) with 25% voltage dip
- Capable of starting 6 hp motor (Nema code G with 25% voltage dip @ 460V)

### SYSTEM OUTPUT

- 3 selector switch modes:
  - Single phase – 120 / 240V Zig Zag
  - Three phase – 120 / 208V Low Wye
  - Three phase – 277 / 480V High Wye

- 78 kW / 78 kVA – standby, single phase
- 72 kW / 72 kVA – prime, single phase
- 88 kW / 110 kVA – standby, three phase
- 80 kW / 100 kVA – prime, three phase

## SYSTEM CONTROLS

- Microprocessor-based controller
  - Backlit, 128x64 pixel resolution display
  - -40°F to 185°F operating temperature range
  - Thermostatically controlled LCD heater
  - Six LED indicators w/ lamp test
    - ◆ Alarm / Fault (Red)
    - ◆ Ready / Manual (Red)
    - ◆ Running (Green)
    - ◆ Warning (Yellow)
    - ◆ Ready / Auto (Green)
    - ◆ Supplying Load (Green)
- Push buttons for easy operation
  - Manual or Auto Start
  - Engine Start or Stop
  - Alarm Cancel & Fault Reset
  - Scrolling Arrows for Diagnostic Information
    - ◆ System kW output display
    - ◆ Line output & frequency display
    - ◆ Engine diagnostic display
      - Oil pressure
      - Engine temperature
      - Fuel level
      - Battery
    - ◆ System hours
      - Running hours
      - kW hours
      - Time to service
  - Alarm list – warnings / shutdowns are date & time stamped
    - ◆ Fuel level: warning – 15%; shutdown – 5%
    - ◆ Overspeed protection: shutdown – 115%
    - ◆ Oil pressure: warning – 25 psi; shutdown – 20 psi
    - ◆ Coolant temperature: warning – 220°F; shutdown – 230°F
    - ◆ Battery voltage: over – 15VDC; under – 11VDC
    - ◆ Generator over voltage: warning – 110%; shutdown – 111%
    - ◆ Generator under voltage: warning – 87%; shutdown – 86%
    - ◆ Generator over frequency: warning – 105%; shutdown – 110%
    - ◆ Generator under frequency: warning – 95%; shutdown – 90%
    - ◆ Over current shutdown

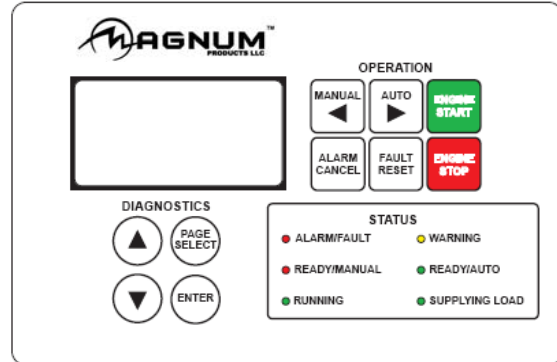

## ELECTRICAL CONTROLS

- Remote start / stop contacts located next to lug box
- Lockable control box door with diagnostics window
- Lockable lug box with safety switch
  - Trips main breaker when lug door is opened
  - Disables voltage regulator
- Cable entry guides to the lug box
  - Restricts access of foreign objects
- Output ground connection lug inside lug box
- 400A main breaker with shunt trip
- Convenience receptacles with individual breakers (restricted use in high wye mode)
  - (2) 120V 20 Amp GFCI duplex outlets (Nema 5-20R type)
  - (3) 125 / 250V 50 Amp, 3 pole, 4 wire twistlock (Non-Nema 6369)
- Panel mounted rheostat for voltage adjustment - +/- 10%
- 720 CCA wet cell battery

## ENCLOSURE

- Aluminum, sound attenuated enclosure
  - UV & fade resistant, high temperature cured, white polyester powder paint
  - Insulated and baffled
  - 68 dB(A) at 23 feet – prime power
- Fully lockable enclosure including doors and fuel fill
- Stainless steel hinges on doors
- Emergency stop switch located on outside of enclosure
- Central lifting point
- Multi-lingual operating/safety decals
- Document holder with operating manual including AC/DC wiring diagrams

## TRAILER

- DOT approved tail, side, brake, and directional lights
  - Recessed rear lights
- Transportation tie downs
- Safety chains with spring loaded safety hooks
- 3" lunette ring hitch
- 6000 lb. axle with surge brakes
- 3000 lb. tongue jack with footplate
- ST225/75R15 tubeless tires – 8 ply



## WEIGHTS & DIMENSIONS

### Skid mounted

- Dry weight: 3549 lbs (1610 kg)
- Operating weight: 4508 lbs (2045 kg)
- 96 x 38 x 62 in (2.44 x 0.97 x 1.58 m)

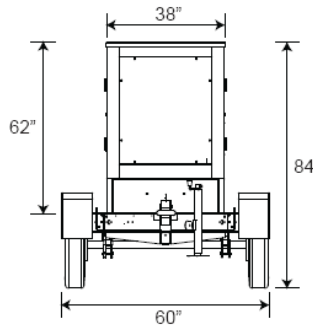

### Trailer mounted

- Dry weight: 4248 lbs (1927 kg)
- Operating weight: 5209 lbs (2363 kg)
- 158 x 60 x 84 in (4.01 x 1.52 x 2.13 m)

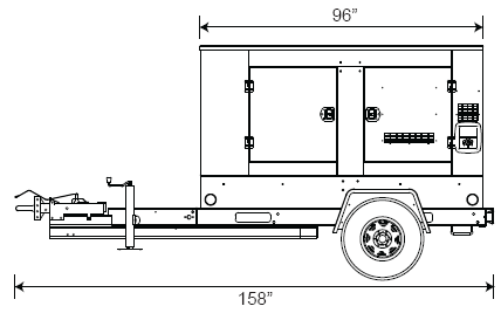

## WARRANTY

- Engine and generator covered under OEM warranty – consult factory for details.

## CERTIFICATIONS

- CSA certified

---

## MMG100 SS Options

### ENGINE OPTIONS

- ◆ In-line engine block heater (Kim Hotstart)
- ◆ Fuel transfer pump

### ELECTRICAL CONTROLS OPTIONS

- ◆ 720 CCA gel cell battery
- ◆ Battery disconnect
- ◆ Battery charger – 2A trickle

### GENERATOR OPTIONS

- ◆ PMG Generator - critical grade power quality

### VOLTAGE OUTPUT OPTIONS

- ◆ 4 position phase switch
  - Single phase – 120 / 240V Zig Zag
  - Three phase – 120 / 208V Low Wye
  - Three phase – 277 / 480V High Wye
  - Three phase – 120 / 240V Delta
- ◆ Dedicated voltage configurations
- ◆ Buck Transformer kit - Provides 120V at GFCI outlets when in 277/480V
- ◆ Cam locks



## SYSTEM CONTROLS OPTIONS

- ◆ Analog gauges
- ◆ Auxiliary strobe/audible indication for soft & hard alarm conditions

## COOLANT OPTIONS

- ◆ 60/40 Coolant - cold weather applications

## ENCLOSURE OPTIONS

- ◆ Fire extinguisher
- ◆ Interior cabinet light
- ◆ Control panel light

## FUEL TANK OPTIONS

- ◆ 36 hr. single wall fuel tank (requires tandem axle trailer)
- ◆ 17 hr. double wall fuel tank
- ◆ 120% Containment

## TRAILER OPTIONS

- ◆ Single axle trailer w/ electric brakes
- ◆ Tandem axle trailer w/ surge brakes
- ◆ Tandem axle trailer w/ electric brakes
- ◆ 6 pin or 7 spade electrical connectors
- ◆ Spare tire/wheel kit

## HITCH OPTIONS

- ◆ 2" ball
- ◆ 2 5/16" ball
- ◆ Adjustable height options:
  - 2" ball
  - 2 5/16" ball

