

## Magnum Mobile Generator – MMG405 SS Specifications

### ENGINE

- John Deere® RG6135HF485 - turbocharged, diesel engine
  - Prime - 489 hp @ 1800 rpm
  - Standby - 538 hp @ 1800 rpm
  - 6 cylinder
  - 13.5 L displacement
  - Tier III approved
- Steel, single wall fuel tank
  - 616 gal. capacity
  - 29 hr. run time – full load
  - Fuel tank built into skid of generator set
- Fuel consumption at prime:
  - 100% - 21.1 gph (79.9 Lph)
  - 75% - 15.8 gph (59.8 Lph)
  - 50% - 10.6 gph (40.1 Lph)
- Cooling system capable of operating at 120°F ambient
- Low coolant shutdown
- Radiator and oil drains plumbed to exterior
- Rubber vibration dampers isolate engine/generator from frame
- In-line engine block heater
- Disposable air filter - paper element
- Air filter restriction indicator mounted on control panel
- 60 Hz engine/generator
- Electronic isochronous governing

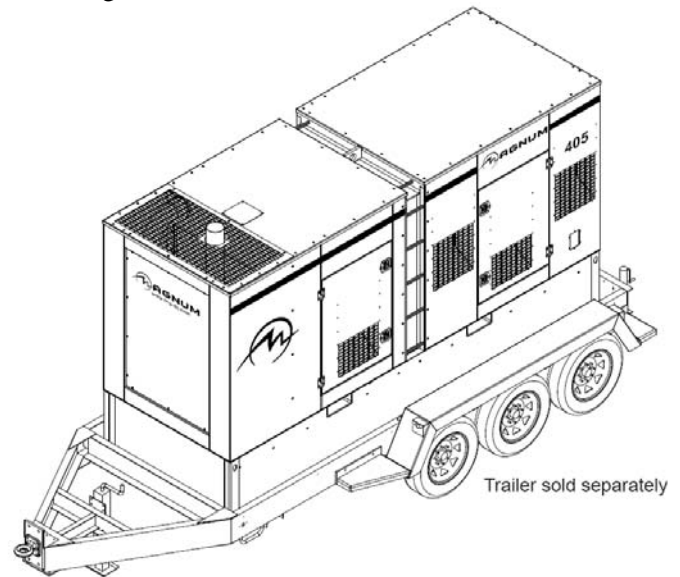

### SUPER START GENERATOR

- Marathon Electric®
  - Brushless
  - 4 pole
  - Class H insulation
- Voltage regulation +/- 1% with Marathon SE350 Voltage Regulator
- Reduces voltage dip on starting events
- Reduces internal operating temperature of the generator
- Increases single motor starting by 89% (compared to standard model)
- 1086 kVA (starting) with 25% voltage dip
- Capable of starting 188 hp motor (Nema code G with 25% voltage dip @ 460V)

### SYSTEM OUTPUT

- Link / Reconnect Board:
  - Three phase – 120 / 208V Low Wye
  - Three phase – 277 / 480V High Wye



- 358 kW / 448 kVA – standby, three phase
- 327 kW / 409 kVA – prime, three phase

## SYSTEM CONTROLS

- Microprocessor-based controller
  - Backlit, 128x64 pixel resolution display
  - -40°F to 185°F operating temperature range
  - Thermostatically controlled LCD heater
  - Six LED indicators w/ lamp test
    - ◆ Alarm / Fault (Red)
    - ◆ Ready / Manual (Red)
    - ◆ Running (Green)
    - ◆ Warning (Yellow)
    - ◆ Ready / Auto (Green)
    - ◆ Supplying Load (Green)
- Push buttons for easy operation
  - Manual or Auto Start
  - Engine Start or Stop
  - Alarm Cancel & Fault Reset
  - Scrolling Arrows for Diagnostic Information
    - ◆ System kW output display
    - ◆ Line output & frequency display
    - ◆ Engine diagnostic display
      - Oil pressure
      - Engine temperature
      - Fuel level
      - Battery
    - ◆ System hours
      - Running hours
      - kW hours
      - Time to service
  - Alarm list – warnings / shutdowns are date & time stamped
    - ◆ Fuel level: warning – 15%; shutdown – 5%
    - ◆ Overspeed protection: shutdown – 115%
    - ◆ Oil pressure: warning – 25 psi; shutdown – 20 psi
    - ◆ Coolant temperature: warning – 220°F; shutdown – 230°F
    - ◆ Battery voltage: over – 15VDC; under – 11VDC
    - ◆ Generator over voltage: warning – 110%; shutdown – 111%
    - ◆ Generator under voltage: warning – 87%; shutdown – 86%
    - ◆ Generator over frequency: warning – 105%; shutdown – 110%
    - ◆ Generator under frequency: warning – 95%; shutdown – 90%
    - ◆ Over current shutdown

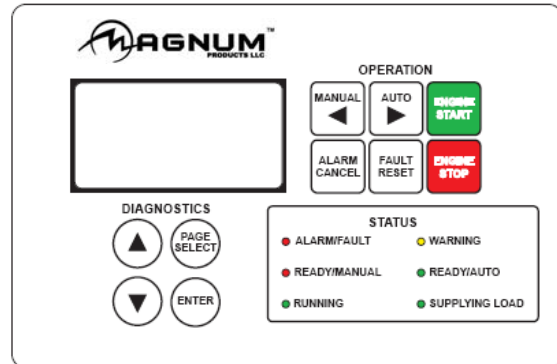

## ELECTRICAL CONTROLS

- Remote start / stop contacts located next to lug box
- Lockable control box door with diagnostics window
- Lockable lug box with safety switch



- Trips main breaker when lug door is opened
- Disables voltage regulator
- Cable entry guides to the lug box
  - Restricts access of foreign objects
- Output ground connection lug inside lug box
- 1600A main breaker with shunt trip
- Convenience receptacles with individual breakers (restricted use in high wye mode)
  - (2) 120V 20 Amp GFCI duplex outlets (Nema 5-20R type)
  - (3) 125 / 250V 50 Amp, 3 pole, 4 wire twistlock (Non-Nema 6369)
  - Buck Transformer kit – Provides 120V at GFCI outlets when in 277/480V
- Panel mounted rheostat for voltage adjustment - +/- 10%
- (2) 1000 CCA wet cell batteries
  - Battery disconnect switch
  - 2A trickle battery charger

## ENCLOSURE

- Aluminum, sound attenuated enclosure
  - UV & fade resistant, high temperature cured, white polyester powder paint
  - Insulated and baffled; 120% containment
  - 68 dB(A) at 23 feet – prime power
- Fully lockable enclosure including doors and fuel fill
- Stainless steel hinges on doors
- Emergency stop switch located on outside of enclosure
- Central lifting point
- Multi-lingual operating/safety decals
- Document holder with operating manual including AC/DC wiring diagrams

## TRAILER

- DOT approved tail, side, brake, and directional lights
  - Recessed rear lights
- Transportation tie downs
- Safety chains with spring loaded safety hooks
- 3" lunette ring hitch
- (3) 8000 lb. axles with electric brakes
- 15000 lb. tongue jack with footplate
- ST215/75R17.5 tubeless tires – 16 ply

## WEIGHTS & DIMENSIONS

Skid mounted

- Dry weight: 12750 lbs  
(5783 kg)
- Operating weight: 17124 lbs  
(7767 kg)
- 175 x 60 x 96 in  
(4.45 x 1.52 x 2.44 m)

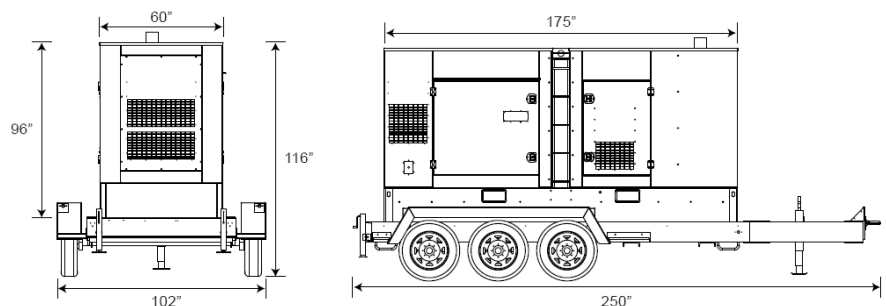

Trailer mounted

- Dry weight: 16000 lbs (7257 kg)
- Operating weight: 20374 lbs (9241 kg)
- 250 x 102 x 116 in  
(6.35 x 2.59 x 2.95 m)

**WARRANTY**

- Engine and generator covered under OEM warranty – consult factory for details.

**CERTIFICATIONS**

- CSA certified

---

**MMG405 SS Options**

**VOLTAGE OUTPUT OPTIONS**

- ◆ Dedicated voltage configurations
- ◆ Cam locks

**SYSTEM CONTROLS OPTIONS**

- ◆ Auxiliary strobe/audible indication for soft & hard alarm conditions

**COOLANT OPTIONS**

- ◆ 60/40 Coolant - cold weather applications

**ENCLOSURE OPTIONS**

- ◆ Fire extinguisher
- ◆ Interior cabinet light
- ◆ Control panel light

**FUEL TANK OPTIONS**

- ◆ 36 hr. single wall fuel tank
- ◆ 13 hr. double wall fuel tank
- ◆ Fuel transfer pump

**TRAILER OPTIONS**

- ◆ 6 pin or 7 spade electrical connectors
- ◆ Spare tire/wheel kit

**HITCH OPTIONS**

- ◆ Adjustable height - 3" lunette ring

