

Magnum Portable Light – MPL2000 Specifications

LIGHT SET

- Two fixtures, metal halide - 1000 watts each
 - Quick disconnect connections
 - Tempered glass lenses
 - Silicone gaskets for moisture protection
- 360° horizontal and vertical rotation
- Individual floodlight switches with GFCI protection
- 120V 20 amp GFCI duplex outlets for auxiliary power
- Weatherproof wire connections, switch and receptacle box
- Galvanized, steel ballast boxes with protective heat shield
- High temperature AMW wiring
- Operating/parts manuals include wiring diagrams

CARRIAGE & MAST

- Steel wheel base
 - 8" hard rubber tires for stability
 - 220 lb. combined wheel capacity
- 2-section, tubular steel mast
 - Easy-to-use winch to extend the mast
 - Equipped with built-in transportation handle
 - UV & fade resistant, high temperature cured, polyester powder paint

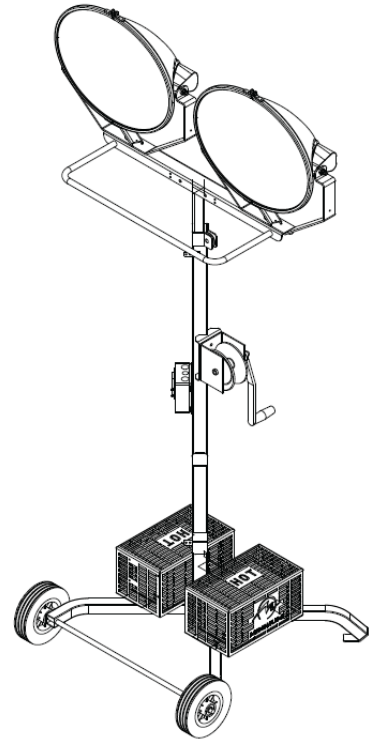

WEIGHTS & DIMENSIONS

- 186 lbs.
- 32.5" x 34.0" – Width of base
- 7 ft. - mast retracted; 11 ft. - mast extended

WARRANTY

- One year – limited warranty

