

## Magnum Trash Pump – MTP4000D Specifications

### ENGINE

- John Deere® PE4024TF281 - turbocharged, diesel engine
  - Continuous - 52 hp @ 1800 rpm
  - Intermittent - 61 hp @ 1800 rpm
  - 4 cylinder
  - 2.4 L displacement
  - Tier IV Interim approved
- Steel, single wall fuel tank
  - 110 gal. capacity
  - 48 hr. run time – full load
  - Fuel tank built into skid of unit
- Fuel consumption at prime:
  - 100% - 2.0 gph (7.6 Lph)
  - 75% - 1.5 gph (5.7 Lph)
  - 50% - 1.0 gph (3.8 Lph)
- Cooling system capable of operating at 120°F ambient
- Rubber vibration dampers isolate engine/pump from frame
- Disposable air filter - paper element
- 720 CCA wet cell battery

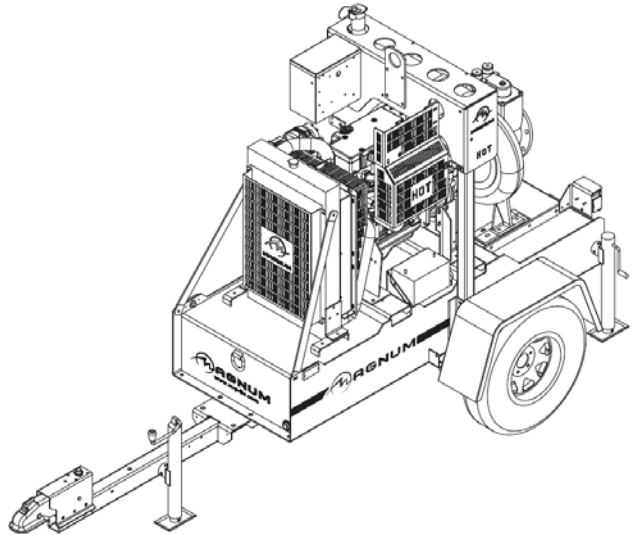

### PUMP

- Dry prime, centrifugal pump
  - 4" NPTF - suction & discharge connection
  - Pump output - 1135 gpm (4296 Lpm)
  - Lift suction - 25 ft. (8 m)
  - Max. diameter of solids - 1.5 in. (38.1 mm)
  - Total dynamic head - 178 ft. (54 m)
- High chrome, cast iron impeller
- Ductile iron volute and wear plate
- Silicon carbide mechanical seal
  - Oil lubricated
- Gray iron bearing housing
- AISI 1045 heat treated shaft
- Spheroidal graphite, ductile cast iron pump casing

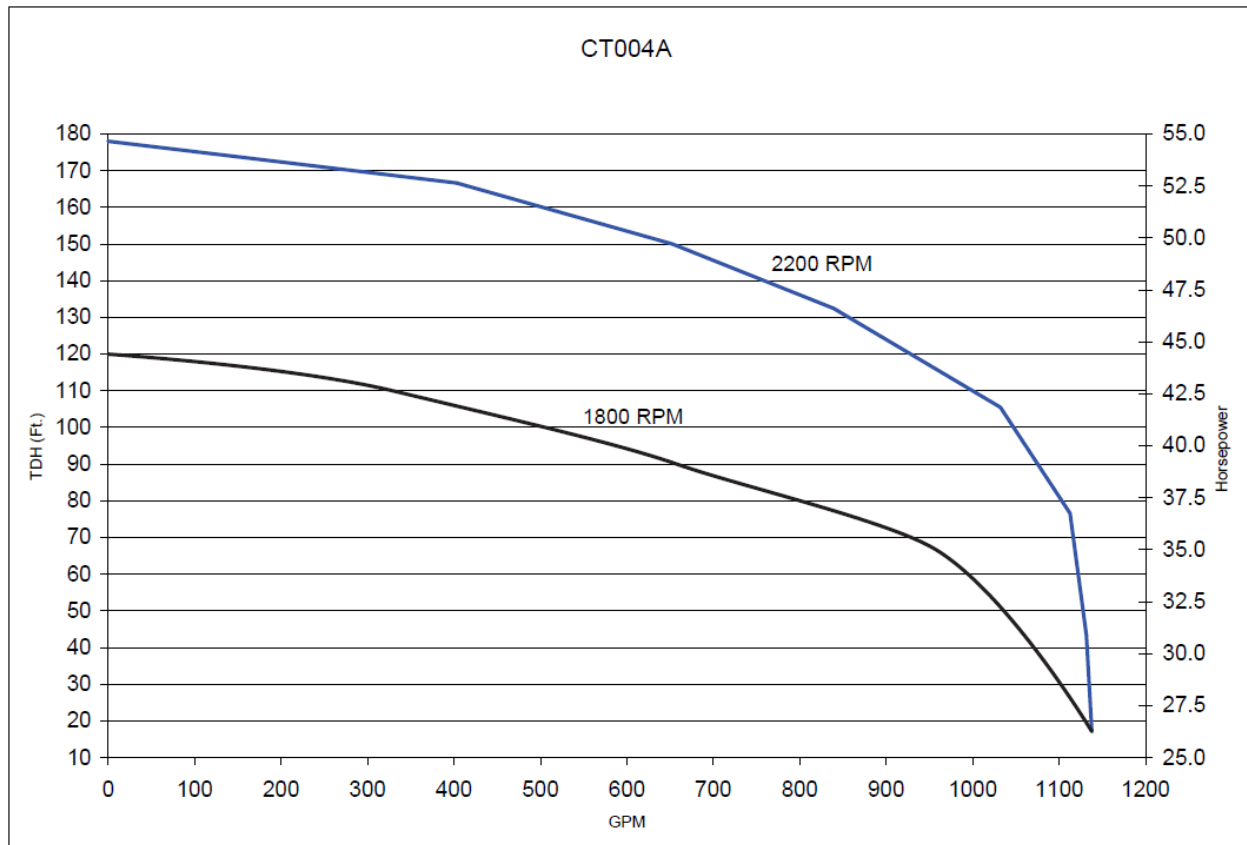

## SYSTEM CONTROLS

- Analog gauge panel - 5 gauges
  - Oil pressure
  - Temperature
  - Fuel level
  - Volts
  - Engine rpm
- Automatic shutdowns
  - Low oil pressure
  - High water temperature
  - Overspeed
  - Overcrank
- Low/high float auto start
- Emergency stop switch located on control panel

## TRAILER

- “Flip-Tongue” design
- DOT approved tail, side, brake, and directional lights
  - Recessed rear lights
- Transportation tie downs
- Safety chains with spring loaded safety hooks
- 2” ball hitch
- 5000 lb. axle with surge brakes



- One 3000 lb. tongue jack with footplate; two 2000 lb. side wind jacks
- ST225/75R15 tubeless tires – 8 ply
- UV & fade resistant, high temperature cured, black polyester powder paint
- 80 dB(A) at 23 feet – continuous power
- Central lifting point
- Multi-lingual operating/safety decals
- Document holder with operating manual including AC/DC wiring diagrams

## WEIGHTS & DIMENSIONS

### Skid mounted

- Dry weight: 1829 lbs (830 kg)
- Operating weight: 2381 lbs (1080 kg)
- 82 x 35 x 60 in (2.08 x 0.89 x 1.52 m)

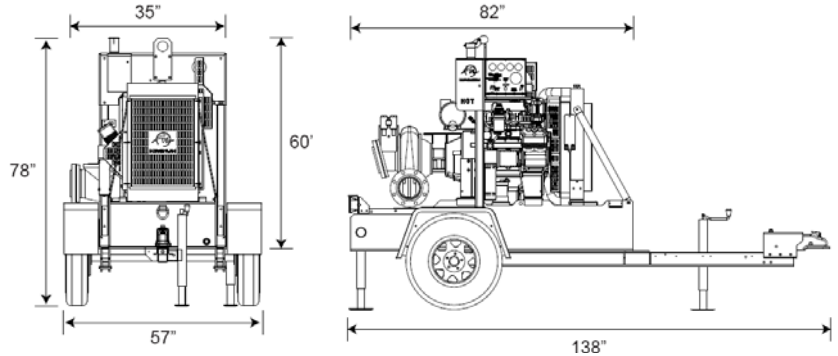

### Trailer mounted

- Dry weight: 2622 lbs (1189 kg)
- Operating weight: 3174 lbs (1440 kg)
- 138 x 57 x 78 in (3.51 x 1.45 x 1.98 m)

## WARRANTY

- Engine and pump covered under OEM warranty – consult factory for details.

## MTP4000D Options

### ENGINE OPTIONS

- ◆ Fuel transfer pump
- ◆ Low coolant shutdown

### ELECTRICAL CONTROLS OPTIONS

- ◆ Low fuel warning/shutdown

### FITTING OPTIONS – INLET & OUTLET

- ◆ Ball & lock ring
- ◆ Galvanized male socket
- ◆ Cam & groove female coupler
- ◆ Cam & groove male coupler
- ◆ NPT 45° male/female weldment

### HITCH OPTIONS

- ◆ 3" lunette ring
- ◆ 2 5/16" ball

