

## Magnum Trash Pump – MTP6000D Specifications

### ENGINE

- John Deere® PE5030TF270 - turbocharged, diesel engine
  - Continuous - 57 hp @ 1800 rpm
  - Intermittent - 67 hp @ 1800 rpm
  - 5 cylinder
  - 3.1 L displacement
  - Tier II approved
- Steel, single wall fuel tank
  - 110 gal. capacity
  - 34 hr. run time – full load
  - Fuel tank built into skid of unit
- Fuel consumption at prime:
  - 100% - 2.8 gph (10.6 Lph)
  - 75% - 2.1 gph (7.9 Lph)
  - 50% - 1.4 gph (5.3 Lph)
- Cooling system capable of operating at 120°F ambient
- Rubber vibration dampers isolate engine/pump from frame
- Disposable air filter - paper element
- 720 CCA wet cell battery
- 70 Amp alternator

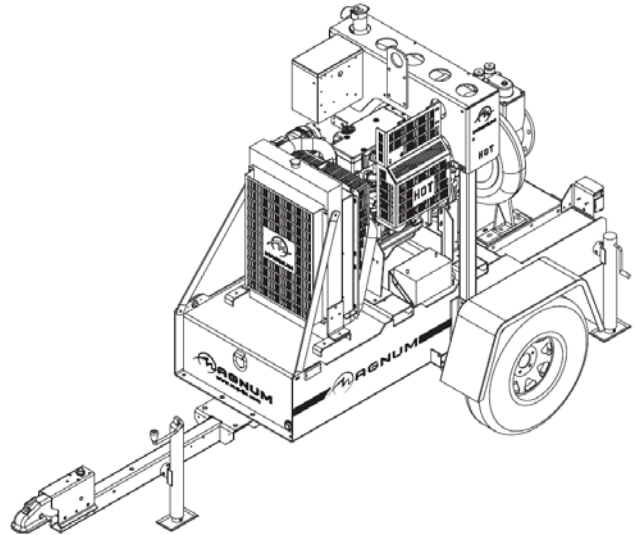

### PUMP

- Dry prime, centrifugal pump
  - 6" NPTF - suction & discharge connection
  - Pump output - 2450 gpm (9274 Lpm)
  - Lift suction - 28 ft. (8.5 m)
  - Max. diameter of solids - 3 in. (76.2 mm)
  - Total dynamic head - 145 ft. (44 m)
- High chrome, cast iron impeller
- Ductile iron volute and wear plate
- Silicon carbide mechanical seal
  - Oil lubricated
- Gray iron bearing housing
- AISI 1045 heat treated shaft
- Spheroidal graphite, ductile cast iron pump casing

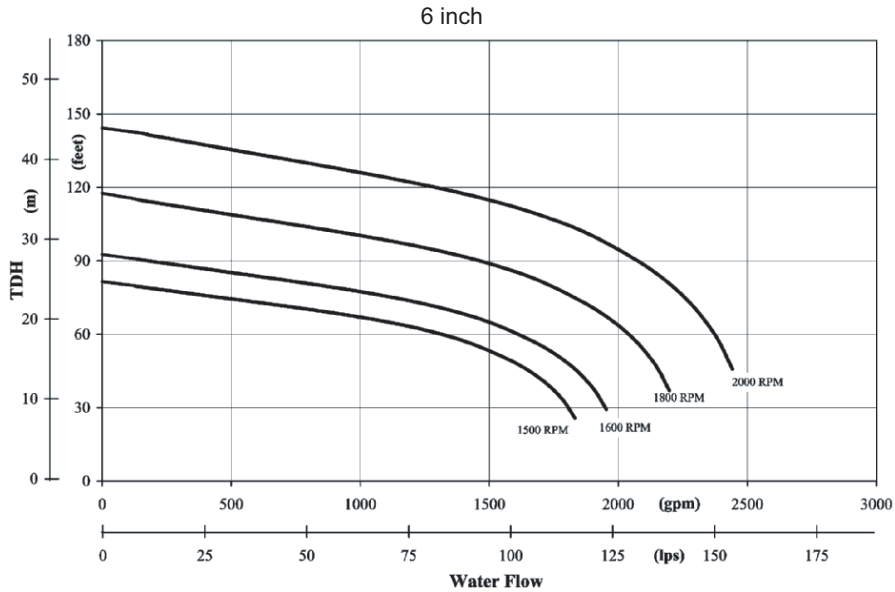

## SYSTEM CONTROLS

- Analog gauge panel - 5 gauges
  - Oil pressure
  - Temperature
  - Fuel level
  - Volts
  - Engine rpm
- Automatic shutdowns
  - Low oil pressure
  - High water temperature
  - Overspeed
  - Overcrank
- Low/high float auto start
- Emergency stop switch located on control panel

## TRAILER

- “Flip-Tongue” design
- DOT approved tail, side, brake, and directional lights
  - Recessed rear lights
- Transportation tie downs
- Safety chains with spring loaded safety hooks
- 2” ball hitch
- 5000 lb. axle with surge brakes
- One 3000 lb. tongue jack with footplate; two 2000 lb. side wind jacks
- ST225/75R15 tubeless tires – 8 ply
- UV & fade resistant, high temperature cured, black polyester powder paint
- 78 dB(A) at 23 feet – continuous power
- Central lifting point
- Multi-lingual operating/safety decals
- Document holder with operating manual including AC/DC wiring diagrams



## WEIGHTS & DIMENSIONS

### Skid mounted

- Dry weight: 2108 lbs (956 kg)
- Operating weight: 2660 lbs (1207 kg)
- 82 x 35 x 60 in (2.08 x 0.89 x 1.52 m)

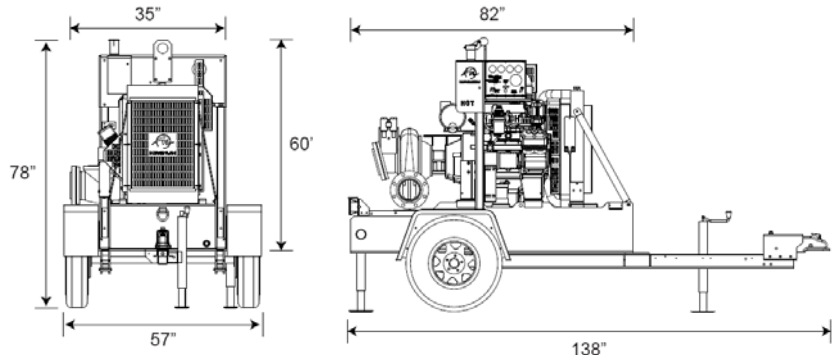

### Trailer mounted

- Dry weight: 2901 lbs (1316 kg)
- Operating weight: 3453 lbs (1566 kg)
- 138 x 57 x 78 in (3.51 x 1.45 x 1.98 m)

## WARRANTY

Engine and pump covered under OEM warranty – consult factory for details.

## MTP6000D Options

### ENGINE OPTIONS

- ◆ Fuel transfer pump
- ◆ Low coolant shutdown

### ELECTRICAL CONTROLS OPTIONS

- ◆ Low fuel warning/shutdown

### FITTING OPTIONS – INLET & OUTLET

- ◆ Ball & lock ring
- ◆ Galvanized male socket
- ◆ Cam & groove female coupler
- ◆ Cam & groove male coupler
- ◆ NPT 45° male/female weldment

### HITCH OPTIONS

- ◆ 3" lunette ring
- ◆ 2 5/16" ball

