

Magnum Trash Pump – MTP6000S Specifications

ENGINE

- John Deere® PE5030TF270 - turbocharged, diesel engine
 - Continuous - 54 hp @ 1800 rpm
 - Intermittent - 63 hp @ 1800 rpm
 - 5 cylinder
 - 3.1 L displacement
 - Tier II approved
- Steel, single wall fuel tank
 - 110 gal. capacity
 - 34 hr. run time – full load
 - Fuel tank built into skid of unit
- Fuel consumption at prime:
 - 100% - 2.8 gph (10.6 Lph)
 - 75% - 2.1 gph (7.9 Lph)
 - 50% - 1.4 gph (5.3 Lph)
- Cooling system capable of operating at 120°F ambient
- Rubber vibration dampers isolate engine/pump from frame
- Disposable air filter - paper element
- 720 CCA wet cell battery
- 70 Amp alternator

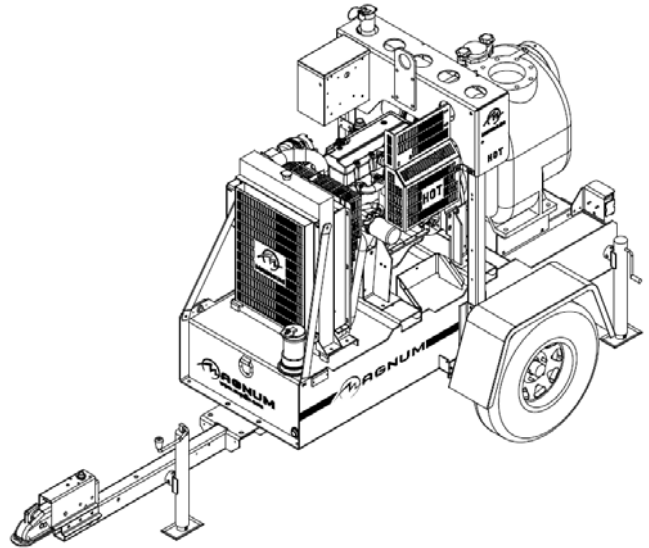

PUMP

- Self-priming, centrifugal pump
 - 6" NPTF - suction & discharge connection
 - Pump output - 1550 gpm (5867 Lpm)
 - Lift suction - 24 ft. (7 m)
 - Max. diameter of solids - 3 in. (76.2 mm)
 - Total dynamic head - 135 ft. (41 m)
- Ductile iron impeller
- Ductile iron volute
- Steel wear plate with stainless hardware
- Silicon carbide mechanical seal
 - Oil lubricated
- Gray iron bearing housing
- Stainless steel shaft
- Ductile cast iron pump casing

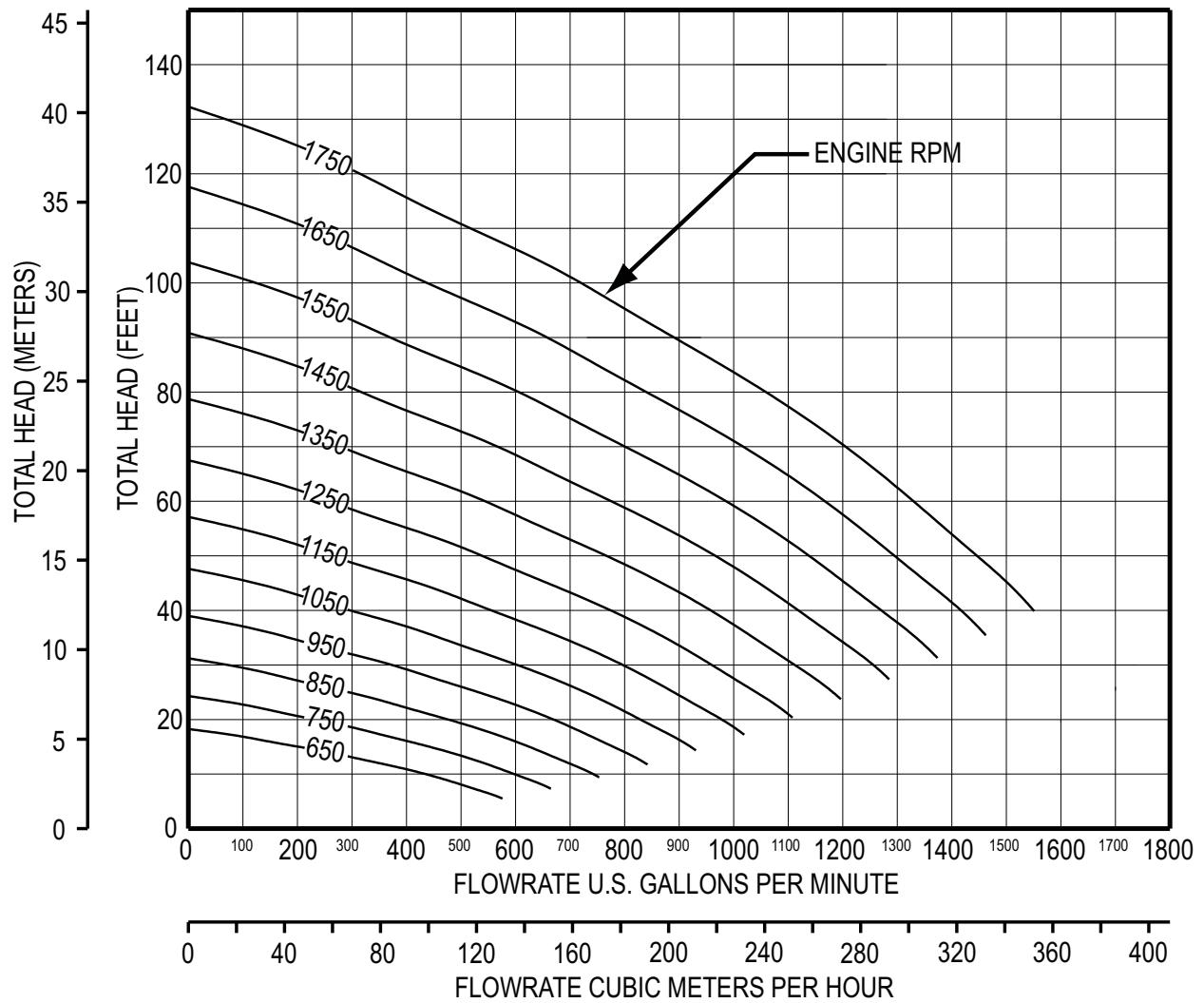

SYSTEM CONTROLS

- Analog gauge panel - 5 gauges
 - Oil pressure
 - Temperature
 - Fuel level
 - Volts
 - Engine rpm
- Automatic shutdowns
 - Low oil pressure
 - High water temperature
 - Overspeed
 - Overcrank
- Emergency stop switch located on control panel
- Low/high float auto start



TRAILER

- “Flip-Tongue” design
- DOT approved tail, side, brake, and directional lights
 - Recessed rear lights
- Transportation tie downs
- Safety chains with spring loaded safety hooks
- 2” ball hitch
- 5000 lb. axle with surge brakes
- One 3000 lb. tongue jack with footplate; two 2000 lb. side wind jacks
- ST225/75R15 tubeless tires – 8 ply
- UV & fade resistant, high temperature cured, black polyester powder paint
- 78 dB(A) at 23 feet – continuous power
- Central lifting point
- Multi-lingual operating/safety decals
- Document holder with operating manual including AC/DC wiring diagrams

WEIGHTS & DIMENSIONS

Skid mounted

- Dry weight: 2698 lbs (1224 kg)
- Operating weight: 3250 lbs (1474 kg)
- 82 x 35 x 60 in (2.08 x 0.89 x 1.52 m)

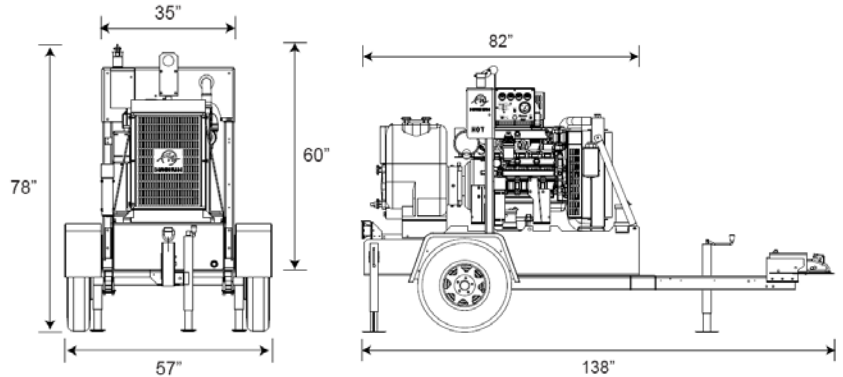

Trailer mounted

- Dry weight: 3491 lbs (1583 kg)
- Operating weight: 4043 lbs (1834 kg)
- 138 x 57 x 78 in (3.51 x 1.45 x 1.98 m)

WARRANTY

Engine and pump covered under OEM warranty – consult factory for details.

MTP6000S Options

ENGINE OPTIONS

- ◆ Fuel transfer pump
- ◆ Low coolant shutdown

ELECTRICAL CONTROLS OPTIONS

- ◆ Low fuel warning/shutdown

FITTING OPTIONS – INLET & OUTLET

- ◆ Ball & lock ring



MTP6000S Specifications Continued:

- ◆ Galvanized male socket
- ◆ Cam & groove female coupler
- ◆ Cam & groove male coupler
- ◆ NPT 45° male/female weldment

HITCH OPTIONS

- ◆ 3" lunette ring
- ◆ 2 5/16" ball

