

## Magnum Trash Pump – MTP6500DFH Specifications

### ENGINE

- John Deere® PE5030TF270 - turbocharged, diesel engine
  - Continuous - 57 hp @ 1800 rpm
  - Intermittent - 67 hp @ 1800 rpm
  - 5 cylinder
  - 3.1 L displacement
  - Tier II approved
- Steel, single wall fuel tank
  - 110 gal. capacity
  - 34 hr. run time – full load
  - Fuel tank built into skid of unit
- Fuel consumption at prime:
  - 100% - 2.8 gph (10.6 Lph)
  - 75% - 2.1 gph (7.9 Lph)
  - 50% - 1.4 gph (5.3 Lph)
- Cooling system capable of operating at 120°F ambient
- Radiator and oil drains plumbed to exterior
- Rubber vibration dampers isolate engine/pump from frame
- Disposable air filter - paper element
- 720 CCA wet cell battery
- 70 Amp Alternator

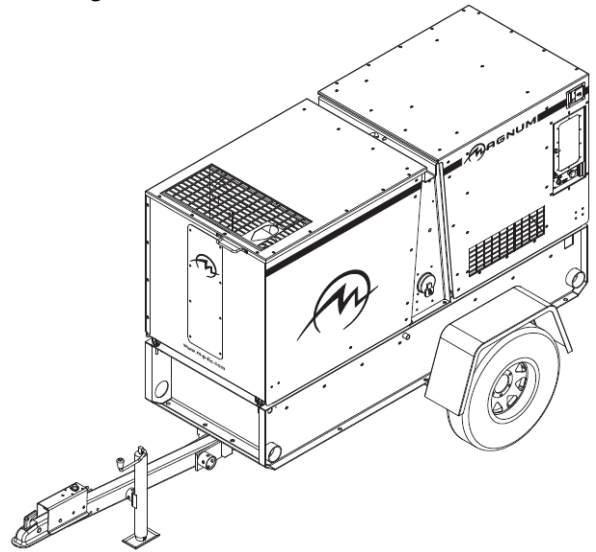

### PUMP

- Dry prime, centrifugal pump
  - 6" NPTF - suction & discharge connection
  - Pump output - 2450 gpm (9274 Lpm)
  - Lift suction - 28 ft. (8.5 m)
  - Max. diameter of solids - 3 in. (76.2 mm)
  - Total dynamic head - 145 ft. (44 m)
- High chrome, cast iron impeller
- Ductile iron volute and wear plate
- Silicon carbide mechanical seal
  - Oil lubricated
- Gray iron bearing housing
- AISI 1045 heat treated shaft
- Spheroidal graphite, ductile cast iron pump casing

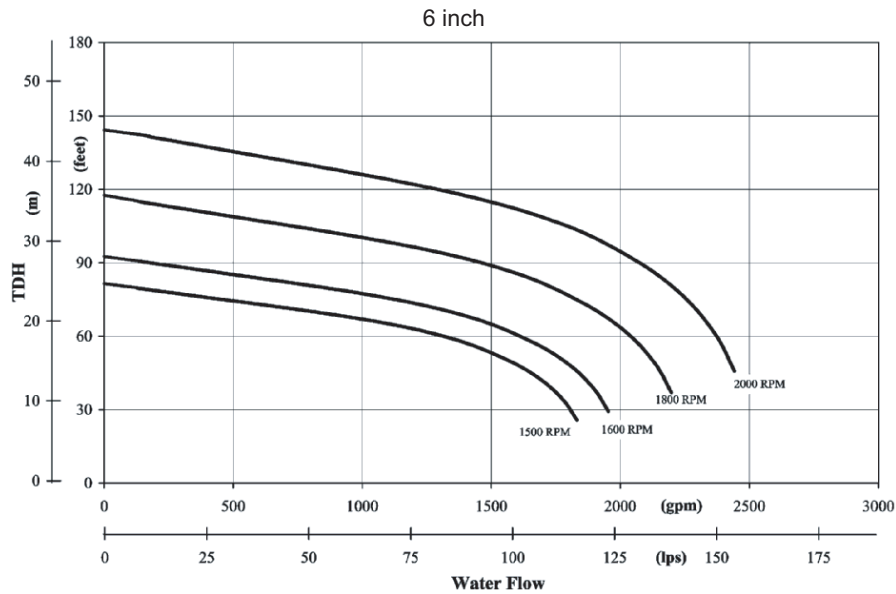

## SYSTEM CONTROLS

- Analog gauge panel - 5 gauges
  - Oil pressure
  - Temperature
  - Fuel level
  - Volts
  - Engine rpm
- Automatic shutdowns
  - Low oil pressure
  - High water temperature
  - Overspeed
  - Overcrank
- Low/high float auto start

## ENCLOSURE

- “Flip-Hood” Patent Pending design - aluminum, sound attenuated enclosure
  - Easy access for daily maintenance
  - Centralized location for all electrical connections/wiring
  - UV & fade resistant, high temperature cured, white polyester powder paint
  - Insulated and baffled
  - 70 dB(A) at 23 feet – continuous power
- Fully lockable enclosure including doors and fuel fill
- Stainless steel hinges on doors
- Emergency stop switch located on outside of enclosure
- Central lifting point
- Multi-lingual operating/safety decals
- Document holder with operating manual including AC/DC wiring diagrams



## TRAILER

- “Flip-Tongue” design
- DOT approved tail, side, brake, and directional lights
  - Recessed rear lights
- Transportation tie downs
- Safety chains with spring loaded safety hooks
- 2” ball hitch
- 5000 lb. axle with surge brakes
- One 3000 lb. tongue jack with footplate; two 2000 lb. side wind jacks
- ST225/75R15 tubeless tires – 8 ply

## WEIGHTS & DIMENSIONS

### Skid mounted

- Dry weight: 2637 lbs (1196 kg)
- Operating weight: 3189 lbs (1447 kg)
- 95 x 35 x 55 in (2.41 x 0.89 x 1.40 m)

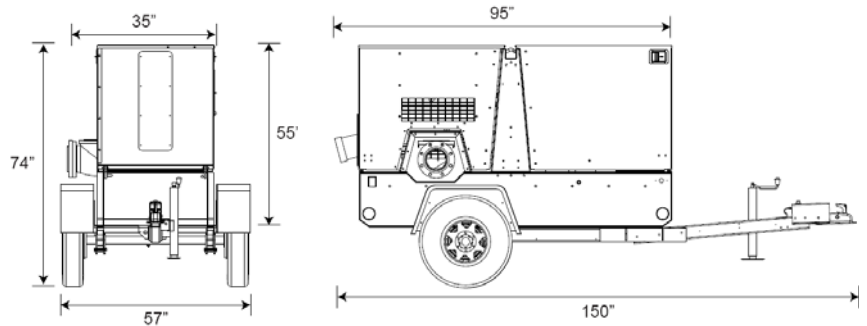

### Trailer mounted

- Dry weight: 3462 lbs (1570 kg)
- Operating weight: 4014 lbs (1821 kg)
- 150 x 57 x 74 in (3.81 x 1.45 x 1.88 m)

## WARRANTY

- Engine and pump covered under OEM warranty – consult factory for details.

---

## MTP6500DFH Options

### ENGINE OPTIONS

- ◆ In-line engine block heater (Kim Hotstart)
- ◆ Fuel transfer pump
- ◆ Low coolant shutdown

### ELECTRICAL CONTROLS OPTIONS

- ◆ Low fuel warning/shutdown
- ◆ 720 CCA gel cell battery
- ◆ 900 CCA wet cell battery
- ◆ Battery disconnect
- ◆ Battery charger – solar powered

### COOLANT OPTIONS

- ◆ 60/40 Coolant - cold weather applications



## **FUEL TANK OPTIONS**

- ◆ 36 hr. single wall fuel tank
- ◆ 120% Containment

## **FITTING OPTIONS – INLET & OUTLET**

- ◆ Ball & lock ring
- ◆ Galvanized male socket
- ◆ Cam & groove female coupler
- ◆ Cam & groove male coupler
- ◆ NPT 45° male/female weldment

## **REMOTE START OPTIONS**

- ◆ 3' cord with quick disconnect
- ◆ Remote start/stop float switches

## **HITCH OPTIONS**

- ◆ 3" lunette ring
- ◆ 2 5/16" ball

