

Magnum Water Trailer – MWT500 Specifications

ENGINE

- Honda® GX120 - 4-stroke, gasoline engine
 - Power – net prime 3.5 hp @ 3600 rpm*
 - Oil alert
 - Auto decompression
 - Recoil cord starter
 - EPA/CARB certified
- Steel, single wall fuel tank
 - .66 gal. capacity
 - 3 hr. run time – full load
- Rubber vibration dampers isolate engine/pump from frame

PUMP

- Self-priming, trash pump
 - 2" suction
 - 2" discharge
 - Output - 8220 gph / 137 gpm
 - Dynamic head - 115 ft.

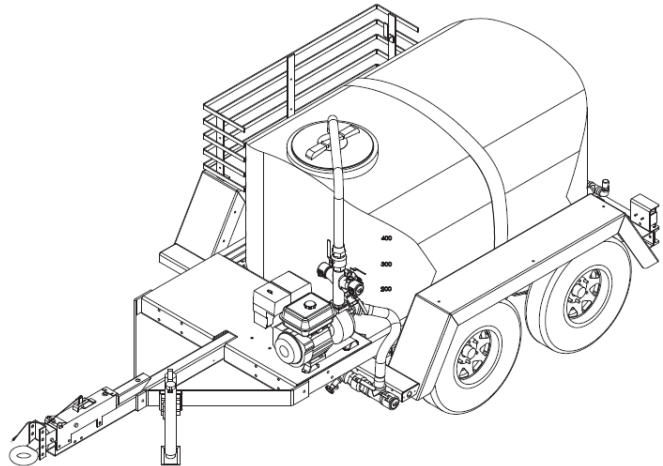

FEATURES & PERFORMANCE

- Polyethylene water tank
 - 500 gallon capacity
 - 3/8" wall thickness
- Steel, zinc-plated upper manifold
- Brass valves and hose bibs
- Multiple fill options available from both sides of unit (hydrant, pond or hose)
 - Fill or dispense selected by turning ball valves; no hose disconnection necessary
 - Fill rate with pond adapter - less than 5 minutes
 - Drain rate with brass spray nozzles - greater than 15 minutes with even water dispersal
- Two (2) brass spray heads on rear of trailer - 120° adjustable spray pattern, 32' range
- Multi-lingual operating/safety decals
- Document holder with operating manual

ADAPTERS & HOSES

- 20' - 2" rigid suction hose with detachable strainer
- 25' - 2" spray hose with spray nozzle
- 50' - 5/8" industrial grade garden hose with sprayer
- Hydrant adapter
- Fender mounted, reversible storage bin

*The power rating of the engine indicated in this document is the net power output tested on a production engine for the engine model and measured in accordance with SAE J1349 at 3600 rpm. Mass production engines may vary from this value. Actual power output for the engine installed in the final machine will vary depending on numerous factors, including the operating speed of the engine in application, environmental conditions, maintenance, and other variables.

TRAILER

- UV & fade resistant, high temperature cured, black polyester powder paint
- DOT approved tail, side, brake, and directional lights
 - Recessed rear lights
- License plate holder with light
- Transportation tie downs
- Safety chains with spring loaded safety hooks
- Single wall, polyethylene fenders
- 3" lunette ring
- (2) 3500 lb. axles with surge brakes
- 2000 lb. tongue jack with footplate
 - Flip tongue for easy shipping
- ST225/75D15 tubeless tires - 8 ply

WEIGHTS & DIMENSIONS

- Dry weight: 1747 lbs (792 kg)
- Operating weight: 5747 lbs (2607 kg)
- 160 x 77 x 64 in
(4.06 x 1.96 x 1.63 m)

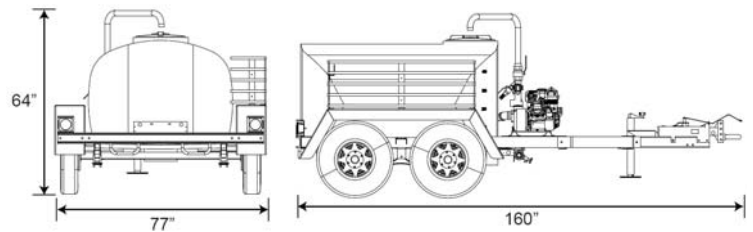

WARRANTY

- Engine and generator covered under OEM warranty – consult factory for details.

MWT500 Options

TRAILER OPTIONS

- ◆ 6 pin or 7 spade electrical connectors
- ◆ Electric brakes

COUPLER OPTIONS

- ◆ 2 5/16" ball
- ◆ 2" - 7000 lb. adjustable ball
- ◆ 2 5/16" - 12,500 lb. adjustable ball
- ◆ 3" pintle hook

HOSE EXTENSION OPTIONS

- ◆ 2" suction strainer
- ◆ 2" suction extensions
 - 10'
 - 20'
- ◆ 2" sprayer extensions
 - 25'
 - 50'
 - 75'

