



MTT20 Supplement



This supplement is meant to be used in conjunction with the Magnum Operating & Parts Manual provided with the unit. Please refer to the Magnum Operating & Parts Manual for complete operation and safety instructions!

Introduction

This supplement is to be used in addition to the Magnum manual (Part Number 40125, Rev. A) received with this unit. Make sure to read and fully understand all safety and operating instructions in the Magnum Operating manual before attempting to operate the equipment.

Table of Contents:

	Page:
Introduction	1
Table of Contents	1
Parts	1

Parts

The following table lists changes to the MTT20 since publication of your manual. The table includes added and deleted parts, as well as when they were changed and the page in the manual that the original (deleted) part can be found. Any part being deleted without adding a part means the part is no longer used on the unit. Any part being added without deleting a part means the part has not previously been used on the unit.

Date	Page No.	Item No.	Part No.	Description	Added	Deleted	Notes
05.21.09	55	N/A	27451	Decal, reflective tape kit - white	1		Added part.
05.21.09	55	N/A	27452	Tape, conspicuity - 2" red/white	22 ft.		Added part.
05.27.09			21674	Engine, Isuzu 4LE1NYGV-01		1	Built Before SN: 0900278
			27293	Engine, Isuzu 4LE2NYGV-01	1		Built After SN: 0900277
			27293	Engine, Isuzu 4LE2NYGV-01		1	Built Before SN: 0900930

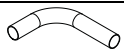
Date	Page No.	Item No.	Part No.	Description	Added	Deleted	Notes
			21674	Engine, Isuzu 4LE1NYGV-01	1		Built After SN: 0900931
06.05.09	42	13	42632	Pipe, tail		1	Incorrect part.
06.05.09	42	13	42632B	Pipe, tail 	1		Corrected part no. & artwork
06.05.09	42	35	42120	Cap, rain		1	Part not used on unit.
07.29.09	26	3	11275	Decal, magnum logo w/web, red vinyl		1	No longer used on unit.
03.10.10	55	51	26578	Brake drum - 12" 8 on 6.5"		1	Incorrect part number.
3.10.10	55	51	22387	Drum, large trailer brake - 6000# axle	1		Corrected part number.
03.10.10	55	61	19965Z	Weldment, jack adapter		1	Incorrect part number.
3.10.10	55	61	11965Z	Weldment, jack adapter	1		Corrected part number.
03.10.10	54-55	All	N/A	Trailer Assembly			New trailer assembly introduced for units built after SN: 1040436. See pages 3-4 of this supplement for a new illustrated parts breakdown.

TRAILER ASSEMBLY (FOR UNITS BUILT AFTER SN: 1040436)

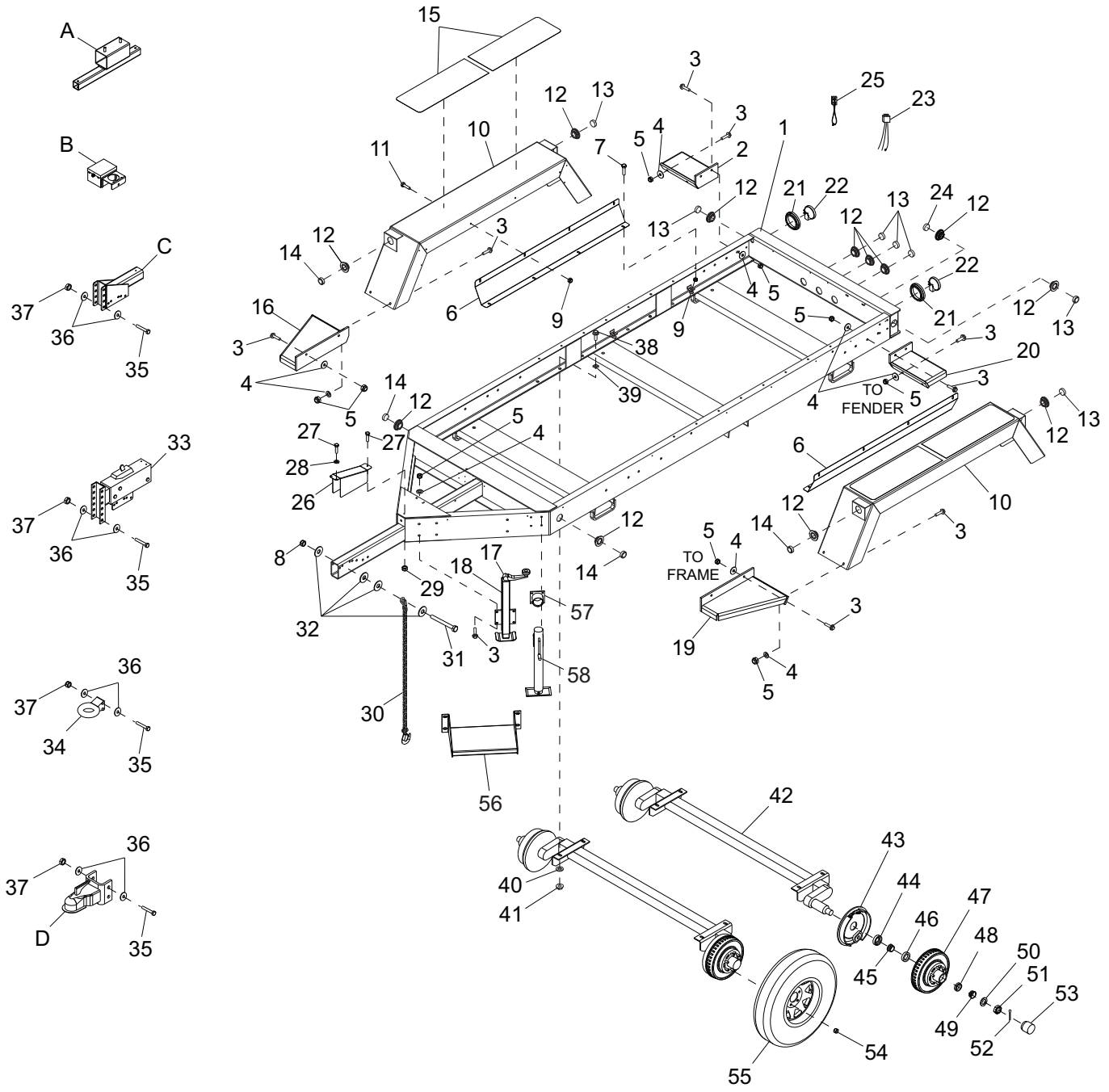

ITEM	PART	QTY	DESCRIPTION	NOTES
1	27655B	1	Weldment, trailer frame	
2	22358B	1	Weldment, rear step rh	
3	61103	20	Screw, .500-13X1.750 sflg hex	
4	60416	20	Washer, .500 flat 1.375/.090	
5	60307	20	Nut, .500-13 nylock	
6	22351B	2	Fender shield, large trailer	
7	60191	8	Screw, M16-2.00X90 std hex G10.9	
8	60668	2	Nut, .500-13 nylk G8	
9	60095	16	Nut, .312-18 sflg case hard	

ITEM	PART	QTY	DESCRIPTION	NOTES
10	27657B	2	Weldment, fender	
11	61091	8	Screw, .312-18X1.000 sflg hex G5	
12	66394	12	Grommet, 2.0"	
13	66397	7	Light, clearance - 2.0" red	
14	66396	4	Light, clearance - 2.0" amber	
15	22398	4	Pad, slip resistant 10" x 28"	
16	22360B	1	Weldment, front step rh	
17	22892	1	Jack, top wind - 5000lb	Jack only
18	22317B	1	Weldment, jack	Includes item 17
19	22359B	1	Weldment, front step lh	
20	22357B	1	Weldment, rear step lh	
21	10221	2	Grommet, 4.5"	
22	10220	2	Light, 4.0" red tail/turn	
23	10222	2	Plug, 3 wire	For tail/turn lights
24	66395	1	Light, utility 2.0"	
25	10226	12	Plug, 2 wire	For clearance lights
26	22302B	1	Cover, brake guard	
27	60684	3	Screw, .250-20X.875 std hex	
28	60286	2	Washer, split lock .250	
29	60144	1	Nut, .250-20 nylock	
30	20159	2	Chain, trailer safety	
31	61099	2	Screw, .500-13X5.00 std hex G8	
32	60671	8	Washer, flat .500 SAE	
33	18373	1	Actuator, trailer	
34	19335B	1	Hitch, pintle eye (adj) - 3" ID	
35	60239	1	Screw, .625-11X5.000 hx	
36	60180	2	Washer, flat .625	
37	60240	9	Nut, .625-11 nylock	
38	61078	8	Screw, .625-11X2.00 flg hex	
39	60651	8	Washer, sqr. bevel structural	.625 galvanized
40	60180	8	Washer, flat .625	
41	60531	8	Nut, .625 - 11 ser flg	
42	22145	2	Axle 6000# - 57" frame	Hydraulic brake
--	22146	2	Axle 6000# - 57" frame	Option: electric brake
43	26571	2	Surge free-backing brake	Left
--	26572	2	Surge free-backing brake	Right
--	26573	2	Electric brake assy	Option: left
--	26574	2	Electric brake assy	Option: right
44	26575	4	Inner grease seal 2.25"	
45	26576	4	Inner hub bearing	
46	26577	4	Inner bearing cup	
47	22387	4	Drum, large trailer brake	6000# axle
48	26584	4	Outer bearing cup	
49	26585	4	Outer hub bearing	
50	26581	4	Spindle washer	
51	12308	4	Spindle nut	
52	26583	4	Spindle nut - cotter pin	
53	26586	4	Dust cap	
54	60096	24	Nut, wheel lug	
55	20374	4	Wheel, 750-16 LTE	
56	13718B	1	Weldment, step	
57	11965Z	4	Weldment, jack adapter	
58	41133	4	Jack, side wind - 2000# tube mount	
--	27451	1	Decal, reflective tape kit	Not shown: white
--	27452	27.7ft.	Tape, conspicuity -2"	Not shown: red/white
--	27671	1	Harness, trailer	Not shown
A	24345B	1	Weldment, spare tire carrier	Option
B	19417	1	Breakaway kit	Option
C	19763B	1	Weldment, hitch elec.	Option: 4-pos adjustable
D	19519	1	Coupler, 2.31 ball	Option: adjustable hitch