

Magnum Products Claim Policy Manual

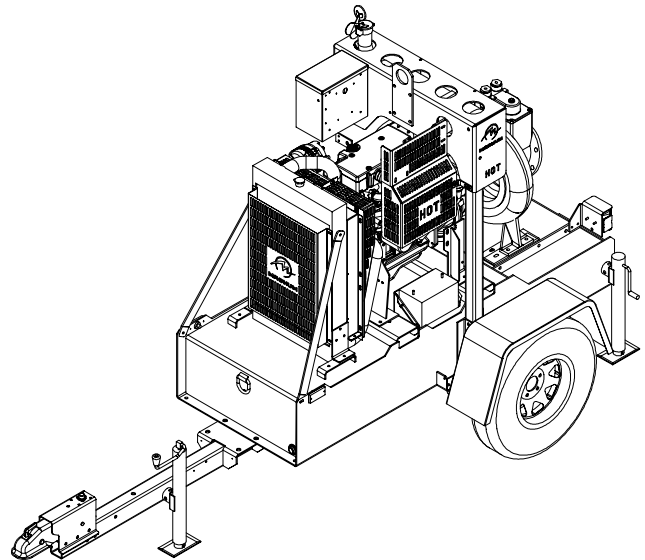
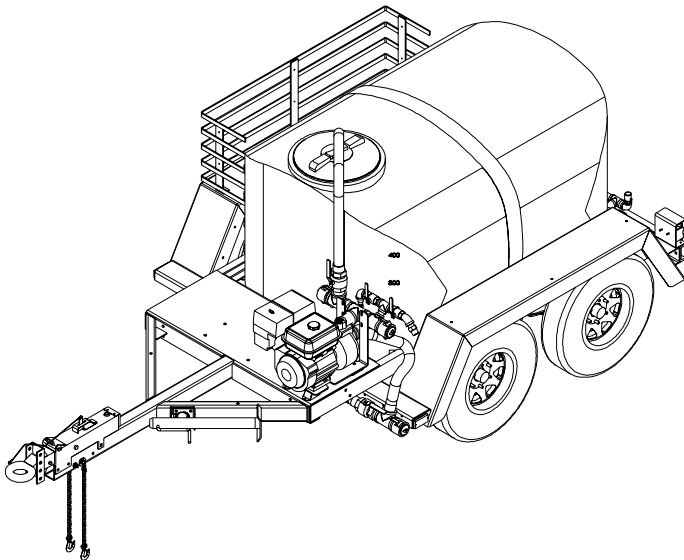

Magnum Products LLC, 215 Power Drive Berlin, WI 54923-2420

Phone: (800) 926-9768 Fax: (920) 920-361-4416

This Magnum policy manual is located in the service section of the company website at www.m-p-llc.com

Table of Contents

Limited Product Warranty

Owner and Warranty	3
Limited Product Warranty Coverage	3
Transfer of Warranty	4
Freight Damage.....	4
Limited Product Warranty Bond	5
Warranty Coverage Overview (Exhibit A).....	6

Limited Parts Warranty

Limited Parts Warranty	7
Ordering Parts	8
Shipping Instructions	8
Drop Shipments.....	8
Parts Substitutions/Shortages	8
Parts Missing on New Equipment	8
Engine and Generator Warranties	9

Damaged Product or Parts

Transit Damage or Loss	10
Visible Damage.....	10
Concealed Damage	10
Refused by Carrier	10

Returning New Parts for Credit

Returned Goods Overview	11
Wrong Parts Ordered/Shipped	11
Billing Errors.....	11
Overstock Items	11

Returned Goods Authorization Form

Purpose	12
RGA Form Example.....	12

Obtaining Credit for Warranty Service

Credit Overview.....	13
Completing the Magnum Products Warranty Claim.....	14
Returning Warranty Parts.....	14
Processing Warranty Credit	14
Foreign Currency	14

Claim Form

Form Sections	15
Claim Form Example	16
Submitting Claims.....	17

Limited Product Warranty

Owner and Warranty

Warranty information is carefully written and it is important that customers understand what is covered and not covered by the warranty. Equally important is the customers' understanding of the obligation to maintain the product with scheduled service. This information should be tactfully communicated to each customer so that they fully understand their responsibilities. Explain in detail the products' capabilities and the potential that mechanical items may need replacement due to normal wear from operation.

Failure to explain the warranty may result in misunderstanding and loss of goodwill when the customer is asked to pay for service that they assumed would be covered by warranty.

Limited Product Warranty Coverage

Warranty coverage under the Limited Product Warranty is limited to product failures that are a result of defects in material or workmanship. Repairs that are necessary due to improper installation, improper load sizing, misuse, abuse, transportation damage, improper service, neglect of service, exposure to the elements, acts of God or causes other than a defect in material or workmanship are not covered by this limited warranty. For specific information on coverage, refer to the product warranty bond on page 5.

The obligation of Magnum Products under this Limited Product Warranty is expressly limited to the repair or replacement of the defective part(s) and does not include the replacement of the complete product. **The Limited Product Warranty does not cover shipping charges or associated transportation charges, damages related to the loss of use, loss of profits, related labor or travel charges, damages to property or equipment or any other incidental or consequential damages.**

The Limited Product Warranty is the only Magnum Products LLC warranty on the product and is in lieu of all other expressed or implied warranties of any kind, including without limitation, any implied warranties of fitness or suitability for a specific purpose.

It is the responsibility of the buyer to carry replacement parts and provide service for the products that they sell. REPLACEMENT PARTS WILL NOT BE SENT TO THE BUYER OR END USER FREE OF CHARGE. To obtain replacement parts, a purchase order must be placed with Magnum Products LLC Parts Sales Department. Magnum Products will ship the replacement part and issue an invoice for the part and associated freight charges.

Continued on next page



Limited Product Warranty, Continued

**Transfer of
Warranty**

The Limited Product Warranty is transferable as long as the new owner of the product is able to provide the original proof of purchase establishing that the product remains within the applicable product warranty period.

**Freight
Damage**

All product and parts are shipped free on board from origin. Loss or damage claims are the responsibility of the buyer. Freight damage is not covered by the Magnum Products LLC Limited Product Warranty.



LIMITED PRODUCT WARRANTY

Subject to the terms and conditions below, Magnum Products, LLC (“Magnum”) warrants that products manufactured by it (other than components subject to an OEM Warranty) (collectively, the “Products”), when used as intended and designed, shall be free from defects in material and/or workmanship for the applicable Warranty Period. Warranty coverage under the Warranty begins on the date of first operation of a Product, or six (6) months after the Product ship date from Magnum and shall continue for the time period(s) set forth in **Exhibit A** (the “Warranty Period”).

Warranty claims must be submitted promptly to Magnum in writing, and actually received within the applicable Warranty Period, describing in detail: (i) the applicable Warranty, (ii) the claimed Product deficiency, defect or failure, (iii) Product information required by Magnum, and (iv) sales or purchaser order for any replacement parts (sent to Magnum’s Parts Sales Department). Magnum will reimburse necessary labor to repair the Products for a reasonable allotment of time to diagnose and replace defective Products as set forth in **Exhibit A**.

Purchaser’s exclusive remedies under this Warranty shall be, at Magnum’s sole discretion: (i) repair; or (ii) replacement; or (iii) payment of or credit for the original purchase price of the Products. These remedies are expressly limited to the repair or replacement of the defective Products (or part(s) thereof), and do not include the replacement of the entire Product. **The Warranty does not cover any incidental costs, including without limitation: shipping or associated transportation charges, travel to and from repair sites, damages related to the loss of use, lost rentals, re-rental expenses and damages to property or other equipment.**

It is the responsibility of the purchaser to carry genuine replacement parts and provide Warranty service for the Products. Magnum will not ship replacement parts to purchasers, or end users, free of charge. Magnum will ship the replacement parts and issue an invoice to purchaser for shipping costs.

The Warranty shall not apply to the extent Product defect has been caused by any of the following: (i) Product operator negligence or intentional misconduct (other than by Magnum), (ii) casualty or accident to the Products; (iii) use and operation of the Products) not in conformance with Magnum’s training and/or operation manuals, or operation exceeding Magnum’s ratings for the Products, including misuse and abuse; (iv) maintenance, service and/or repair of the Products not in conformance with Magnum’s recommended service and maintenance schedules; (v) improper installation (other than by Magnum) not in material conformance with Magnum’s specifications; (vi) unauthorized modification of or alternations to the Products; (vii) improper load sizing (other than by Magnum); (viii) transportation damage; or (ix) Product exposure to the elements or other acts of God.

Engines and driven components used in all Magnum Products carry a separate manufacturer’s (OEM) warranty (the “OEM Warranties”), unless otherwise expressly stated. OEM Warranties are in addition to this Warranty. All warranty claims for defects in material and/or workmanship on Magnum’s Products’ components, must be directed through the OEM distributor/dealer network. OEM Warranties may vary and are subject to change. Magnum shall have no liability under OEM warranties. Please contact your local Magnum sales representative for a list of these providers.

The express warranties provided herein are offered in lieu of all other warranties, and to the greatest extent permitted by applicable law, Magnum’s repair and/or replacement of the Products, shall be purchaser’s sole and exclusive remedies and Magnum shall have no additional obligations. **MAGNUM MAKES NO WARRANTY, REPRESENTATION OR GUARANTEE TO PURCHASER OR ANY THIRD PARTY EXCEPT AS EXPRESSLY PROVIDED IN AND BY THIS WARRANTY. MAGNUM HEREBY EXPRESSLY DISCLAIMS ANY WARRANTY OF MERCHANTABILITY OR OF FITNESS FOR A PARTICULAR PURPOSE (OR OTHER WARRANTIES, REPRESENTATIONS OR GUARANTEES ARISING BY OPERATION OF LAW, COURSE OF DEALING OR CUSTOM OF TRADE). MAGNUM SHALL NOT BECOME LIABLE UNDER ANY CIRCUMSTANCES WHATSOEVER (WHETHER BY VIRTUE OF A PURCHASE AGREEMENT, THIS WARRANTY, ANCILLARY AGREEMENTS ENTERED INTO IN CONJUNCTION WITH THE FOREGOING OR ANY OTHER DOCUMENTS) FOR SPECIAL, EXEMPLARY, CONSEQUENTIAL, INCIDENTAL, PUNITIVE OR SPECULATIVE DAMAGES, INCLUDING WITHOUT LIMITATION PURCHASER’S OR ANY THIRD PARTIES’ LOST PROFITS WHICH MAY RESULT FROM, BE CAUSED BY OR ARISE OUT OF: (I) BREACH OF ANY WARRANTY, REPRESENTATION OR GUARANTEE MADE BY MAGNUM; (II) THE USE, OR COST OF USE, OF THE PRODUCTS; OR (III) MAGNUM’S PERFORMANCE OF ANY REMEDIAL WORK REQUIRED BY THIS WARRANTY.**

Some states in the U.S.A. do not allow limitations of how long an implied warranty extends, or the exclusion of incidental, indirect, special or consequential damages, so that the above limitation or exclusion may not apply to you. In some Canadian provinces legislation provides for certain additional warranties or remedies other than as stated herein, and to the extent that they may not be waived, the limitations and exclusions set out above may not apply. This Warranty provides specific legal rights; other rights may be available, but may vary from state to state or from province to province. gb132608_2 10/2006

Warranty Coverage Overview (Exhibit A)

MMG Product Line

<u>Entire Product*:</u>	1 year/ unlimited hours 2 years/ 2000 hours
*Exceptions:	glow plugs, filters, fuses, bearings, brakes, fluids, tires, belts
<u>Engine OEM Warranty**</u>	
John Deere:	1 year: unlimited hours 2 years: 2000 hours
Isuzu:	1 year: unlimited hours 2 years: electrical 5 years: 5000 hours: cylinder block, head, crankshaft, camshaft, gears, connecting rods, flywheel, oil pan, intake/ exhaust manifold

** Warranty provided by engine manufacturer

MLT & MLG Product Line

<u>Entire Product*:</u>	1 year: unlimited hours 2 years: 2000 hours
*Exceptions:	glow plugs, filters, fuses, light bulbs, bearings, fluids, tires, generator capacitors, belts
<u>Engine OEM Warranty**</u>	
Mitsubishi:	1 year: unlimited hours 3 years: 3000 hours 5 years: 5000 hours: crankcase, crankshaft, connecting rods, head, camshaft, flywheel, oil pan, intake/ exhaust manifold
Lombardini:	2 years: 1500 hours
CAT:	1 year: unlimited 2 years: 2000 3 years: 3000: cylinder block, head, crankshaft, camshaft, connecting rods
Kubota:	2 years or 2,000 hours
Isuzu:	1 year: unlimited hours 2 years: electrical 5 years: 5000 hours: cylinder block, head, crankshaft, camshaft, gears, connecting rods, Flywheel, oil pan, intake / exhaust manifold

** Warranty provided by engine manufacturer

MWT Product Line

<u>Entire Product*:</u>	1 year: unlimited hours
*Exceptions:	spark plugs, engine recoil, trailer lights, filters, fuses, hoses, seals, tires, brakes, bearings, fluids, belts

MPL Product Line

<u>Entire Product*:</u>	1 year: unlimited hours
*Exceptions:	light bulbs

MTP Product Line

<u>Entire Product*:</u>	1 year: unlimited hours 2 years: 2000 hours
*Exceptions:	glow plugs, filters, fuses, bearings, brakes, fluids, tires, belts
<u>Engine OEM Warranty:</u>	See John Deere engine warranty above

Consult Magnum Products LLC to determine eligibility of battery coverage.

Limited Parts Warranty

Limited Parts Warranty

Magnum Products genuine replacement parts are covered by a six (6) month Limited Parts Warranty when properly installed on Magnum Products LLC equipment. If Magnum parts are installed during the terms of the Limited Product Warranty, the parts are covered for the remaining term of the Limited Product Warranty or six months from date of installation, whichever is greater. In all other cases, the term of the Limited Parts Warranty is six months from the date of installation.

Magnum replacement parts installed on, or used with, any product not manufactured by Magnum Products LLC are not covered by the Limited Parts Warranty. The Limited Parts Warranty is limited to part failures resulting from defects in material or workmanship. Any failure of parts due to improper installation, improper load sizing, misuse, abuse, transportation damage, improper service, neglect of service, exposure to the elements, acts of God or causes other than a defect in material or workmanship are not covered by this limited part warranty.

The obligation of Magnum Products under this Limited Product Warranty is expressly limited to the repair or replacement of the defective part(s) and does not include the replacement of the complete product. **The Limited Product Warranty does not cover shipping charges or associated transportation charges, damages related to the loss of use, loss of profits, related labor or travel charges, damages to property or equipment or any other incidental or consequential damages.**

The Limited Product Warranty is the only Magnum Products LLC warranty on the product and is in lieu of all other expressed or implied warranties of any kind, including without limitation, any implied warranties of fitness or suitability for a specific purpose.

In the event a genuine Magnum Part fails within the terms of the Limited Parts Warranty, credit will be issued to the buyer upon receipt of a claim form. A claim form must be filed to receive credit for parts. Also, a part may need to be returned to Magnum Products LLC for examination. To obtain replacement parts, a purchase order must be placed with Magnum Products LLC Parts Sales Department. Magnum Products will ship the replacement part and issue an invoice for the part and associated freight charges. Replacement parts will not be sent to the buyer or end user free of charge.

Continued on next page

Limited Parts Warranty, Continued

Ordering Parts

Parts may be ordered by the following methods:

On-line	Fax	Phone
<p>http://www.m-p-llc.com using SmartEquip.</p> <p>If you do not have a SmartEquip Username and Password one can be obtained from Magnum Customer Service at (800) 926-9768.</p>	<p>(920) 361-2214</p> <p>Must include buyer name, contact person, phone, fax and e-mail address. List the Part Quantity, Part Number and Part Description from left to right across the page.</p>	<p>(800) 926-9768.</p> <p>If parts information is requested, please have your full model number and serial number available.</p>

Shipping Instructions

Shipping instructions must be clearly written on every parts order. Blanket shipping instructions will not be recognized. Magnum Products LLC will determine the means of transportation on orders where shipping instructions were not specified.

Drop Shipments

Orders for drop shipments to the end user will not be accepted. Requests for exceptions to this policy will be evaluated by Magnum Products LLC, on a case by case basis, in emergency situations.

Parts Substitutions

Magnum Products reserves the right to make part substitutions without notice.

Parts Shortages

Shortages on parts orders that are a result of an error by Magnum Products LLC must be reported using a claim form in writing within 30 days of receipt of shipment. Magnum Products LLC, reserves the right to make partial shipments without notice.

Parts Missing on New Equipment

The buyer must file a separate Product Warranty Claim indicating what part was missing.

Continued on next page

Limited Parts Warranty, Continued

Engine and Generator Warranties

Engines and Generators used in all Magnum products carry the original equipment manufacturer (OEM) warranty unless stated otherwise. These warranties are handled through the OEM distributor/dealer network. OEM warranties may vary and are subject to change. **Contact Magnum Products LLC, for the nearest OEM representative.** These warranties are in addition to the Magnum Limited Product Warranty and the Magnum Limited Parts Warranty. Magnum Products LLC provides a link to all major suppliers' web sites under the Service section at www.m-p-llc.com.

Original Equipment Manufacturer	Link
Marathon Electric	http://www.marathonelectric.com/generators/parts_svc/gen_serv.htm
John Deere	Engine Registration: http://jdpswarranty.deere.com/warranty/ Dealer Locator: http://dealerlocator.deere.com/servlet/DealerLocator
Mitsubishi	http://www.mitsubishi-engine.com/
Kohler Engines	http://www.kohlerengines.com/service/support/index.jsp
Isuzu	http://www.isuzuengines.com/Distributor/distributors_na_map.htm
Honda	http://www.honda-engines.com/dea.htm
MECC Alte Spa	http://www.meccalte.it/eng/reteassist.asp
Zenith Transfer Switches	http://www.geindustrial.com/cwc/products?famid=3

All of the above sites are also linked at: <http://www.m-p-llc.com/services.htm>

Damaged Products or Parts

**Transit
Damage or
Loss**

All merchandise is accepted and assumed to be in good condition by the carrier. All shipments must be examined for possible damage as soon as they are delivered by the carrier.

Shipments cannot be refused due to damage. THE SHIPMENT MUST BE ACCEPTED AND A CLAIM FILED WITH THE CARRIER. Magnum Products LLC can assist the buyer with the claim but accepts no responsibility for the damage. Freight damage is NOT covered by the Magnum Limited Product Warranty or Magnum Limited Parts Warranty.

**Visible
Damage**

Damage that is visible at the time of delivery *must be noted on the original transportation receipt with the driver's signature*. A careful examination of the exterior and interior of the product should be performed immediately.

**Concealed
Damage**

Concealed damage is damage that is not discovered until the product is unpacked and internal examination of the cabinetry is made. As soon as concealed damage is discovered, the carrier must be notified in writing and an inspection requested. The inspector will file a report called a 'Report of Loss or Damage to Freight Inspected After Delivery.'

**Refused by
Carrier**

Refer to the table below, which summarizes how to handle coverage refused by a carrier:

If the carrier refuses payment of a transit damage claim and...	Then submit to Magnum Products for consideration...
Damage is Visible	<ol style="list-style-type: none"> 1. Original bill of lading 2. Original product invoice 3. Photographs of damage
Damage is Concealed	<ol style="list-style-type: none"> 1. Original bill of lading 2. Original product invoice 3. Photographs of damage 4. <i>Inspection reports signed by carrier</i>

Returning New Parts for Credit

Returned Goods Overview

Magnum Products LLC reserves the right to accept or deny requests for returning overstock and unneeded parts. All parts eligible for return credit must be in new, saleable condition. No credit will be considered for parts that have been used, mistreated or appear shopworn.

The customer must provide a copy of the original Magnum Products LLC parts sales order number or invoice number.

If a new part is not needed and the customer wishes to return for credit, a request must be made to our parts sales department. **DO NOT RETURN PARTS WITHOUT A RETURN AUTHORIZATION.** The request can be made by telephone, fax or e-mail. Magnum Products LLC will then evaluate the part involved and determine if it is an item Magnum can accept for return.

If the part needs to be returned to Magnum Products LLC, a Returned Goods Authorization (RGA) form will be issued to the customer. This authorization must accompany the part so that it is properly identified in our system. If a part is received without an RGA form and we cannot identify the reason for return, no credit for the part can be issued.

An RGA is valid for 60 days after issued. In the event a part is not returned during this timeframe, a new RGA will need to be issued. All parts returned to Magnum Products LLC for credit consideration must be properly packaged to protect them during transit. If parts are received damaged, no credit can be issued.

Wrong Parts Ordered

If a customer orders the wrong part number or the incorrect quantity of parts, the parts are eligible for return, less a 20% restocking fee. In the event we provided the wrong information to the customer, resulting in an order error, the 20% restocking is waived. A claim form must be filed to receive credit.

Wrong Parts Shipped

If a customer orders a part and Magnum Products LLC ships a different part in error, the customer will receive credit for the item, including shipping. A claim form must be filed to receive credit, and an RGA form issued.

Billing Errors

If there is a discrepancy in pricing, quantities of parts, shipping, etc. between the original customer purchase order and the Magnum sales invoice, please notify the parts sales department. A claim form must be filed to receive credit.

Overstock Items

After a period of months, if an item is not moving, the customer may request to return the overstock to Magnum Products LLC. A list of the items in question needs to be forwarded to Magnum for consideration. Any parts accepted for credit must be current sale items and must be in new, saleable condition. All overstock items will be subject to a 20% restocking fee.



Returned Goods Authorization (RGA) Form

Purpose

The RGA Form is issued by Magnum Products LLC and is to be used any time a part needs to be returned to Magnum Products LLC.

The warranty department will issue and send an RGA form to the customer. The RGA form must be packaged with the warranty part to identify the correct warranty claim in order to be processed. The RGA is valid for 60 days from the date issued, so it is important to send in the warranty part promptly.

Example

Below is an example of the RGA Form.



RGA FORM

EMPOWERING REAL PEOPLE

Request Code: A - Product Warranty B - Part Warranty C - Ordered Incorrectly D - Shipping Error
 F - Customer Request Return (20% restocking charge will apply) G - Evaluation

Customer:	RGA #:
Attn:	Issue Date:
Address:	Claim #:
	Customer ID #:
Phone:	Unit Model #:
Fax:	
E-mail:	

Qty	Part #	Description	Sales Order #	Cost (U.S. \$)	Qty rec'd	Initial	Date

Unit Information

Unit Serial #:
Unit Hours:
Description of failure:
Filed warranty: Y or N

**PLEASE SHIP ALL REQUESTED PARTS TO: Magnum Products LLC
215 POWER DRIVE
BERLIN WI 54923-2214**

RGA:

Be sure to clearly identify the RGA number on the outside of your package near shipping label.

Notes / Follow-up:

Authorized By: _____

Magnum Products LLC 215 Power Drive, Berlin, WI 54923-2214 Ph: 800-926-9768 Fax: 920-361-2214
www.m-p-llc.com

Obtaining Credit for Warranty Service

Credit Overview

Warranty coverage on all units produced by Magnum Products LLC is limited to product failures resulting from defects in material or workmanship. Repairs necessary due to improper installation, improper load sizing, misuse, abuse, transportation damage, improper service, lack of maintenance, neglect of service issue, exposure to the elements, acts of God or causes other than a defect in material or workmanship are not covered by this Limited Product Warranty.

Warranty coverage under the Limited Product Warranty begins on the date of first operation or 6 months after the product ship date from Magnum Products LLC.

The obligation of Magnum Products LLC under this Limited Product Warranty is expressly limited to the repair or replacement of the defective part(s) and does not include the replacement of the complete product. **The Limited Product Warranty does not cover any Incidental Costs which include: shipping or associated transportation charges, travel to and from repair sites, damages related to the loss of use, loss of profits, lost rentals, re-rental expenses, damages to property or other equipment and all incidental or consequential damages.** The Limited Product Warranty is the only Magnum Products LLC warranty on the product and is in lieu of all other expressed or implied warranties of any kind, including without limitation, any implied warranties of fitness or suitability for a specific purpose.

It is the responsibility of the buyer to carry genuine replacement parts and provide warranty service for the products that they sell. MAGNUM PRODUCTS LLC WILL NOT SEND REPLACEMENT PARTS TO THE BUYER OR END USER FREE OF CHARGE. To obtain replacement parts under warranty, a purchase order must be placed with Magnum Products LLC parts sales department. Magnum Products LLC will ship the replacement parts and issue an invoice for the parts order.

Engines and Driven Components used in all Magnum Products LLC products carry the OEM warranty unless otherwise stated. The OEM Engine and Driven Components warranties are in addition to the Magnum Products LLC Limited Product Warranty. All warranty claims for defects in material and workmanship on these parts must be directed through the OEM distributor/dealer network. OEM warranties may vary and are subject to change. Please contact your local Magnum Products LLC sales representative for a list of these providers.

For specific details on warranty coverage, please consult the Magnum Products LLC warranty bond on pages 5-6.

Continued on next page

Obtaining Credit for Warranty Service, Continued

Completing the Magnum Products Warranty Claim

To obtain credit for the replacement parts under warranty, a completed claim form must be submitted. The claim form must reference all required product information and the sales order for the replacement parts. Reimbursement for labor to repair the product will be for a reasonable allotment of time to diagnose and replace defective components.

The claim form is available electronically on the Magnum Products LLC website. A completed claim can be e-mailed as an attachment to the Magnum Products LLC warranty department for fast processing at warranty@m-p-llc.com. The form can also be printed out and faxed or mailed.

It is important that warranty claims be filed promptly with Magnum Products LLC. Claims that are pending for over 90 days from the date of the repair may not be considered for credit.

Returning Warranty Parts

All parts replaced under warranty must be held until a credit memo is received for the repair. Upon receipt of the credit, the parts can be scrapped at the customer's location.

To assist our corrective action efforts, there may be instances where Magnum Products LLC will require the return of a defective warranty part in order to process the claim. When this occurs, the warranty department will issue an RGA form to the customer. The RGA form must be packaged with the warranty part to identify the correct warranty claim in order to be processed. The RGA is valid for 60 days from the date issued and therefore it is important to send in the warranty part promptly.

Processing Warranty Credit

When completing a Magnum Products LLC warranty claim, it is important to identify the complete name and address of the company and list the correct branch location to which credit is issued.

Upon processing the warranty claim, a credit memo is issued to the customer. The credit memo will provide details on the parts ordered for the repair and the amount of labor being reimbursed.

In the event the customer has questions regarding warranty coverage, the status of specific claims or the amount of credit received for repairs, please contact the Magnum Products LLC warranty department for assistance.

Foreign Currency

Credit given in a currency other than U.S. dollars will be issued at the exchange rate on the day credit is issued.

Claim Form

Purpose The purpose of the claim form is to allow customers to receive credit as applicable under the Magnum Products LLC Limited Product Warranty.

Sections The Claim Form is explained below according to section. An example of the claim form is on the next page numbered by section.

Section 1

Fill in the proper request code and date. Magnum Products LLC, reserves the right to accept or deny requests for overstock parts returns, restocking fees may apply.

Code	Description
A – Product Warranty	Parts originally installed on a unit during the manufacturing process.
B – Part Warranty	Parts installed after the Product Warranty expiration that have failed within six months.
C – Ordered Incorrectly	Parts ordered incorrectly by the buyer.
D – Shipping Error	Parts shipped in error, parts with the incorrect part number.
E – Billing Error	Discrepancy in part invoices (attach copy of the invoice)
F – Requested Return	Requests by the buyer to return parts or product.
H – Evaluation	Evaluation

Section 2

Your Magnum Customer ID Number and company information must be provided for the claim to be processed. The Customer Reference Number is for tracking the claim in the customers' system. Customer information must also be listed if the product has been sold into the retail market or to specify the branch where the product is located.

Section 3

Product information must be complete. Service technicians must be trained to record all pertinent information at the time of service.

Section 4

Part failure information is important. Technicians must include detailed information regarding the failure. Important: The Shipment Order Number (SO#) or Invoice Number must be included.

Section 5

Explain what work was performed to repair or replace a part. Specific descriptive words and technical detail must be included to expedite the processing of the claim for the amount indicated.

Continued on next page



Claim Form, Continued

Section 6

Magnum Products LLC use only.

Example

1

2

3

4

5

6

MAGNUM PRODUCTS LLC		Claim Form <i>EMPOWERING REAL PEOPLE</i>			
Request code: <input type="checkbox"/> A - Product Warranty D - Shipping Error		<input type="checkbox"/> B - Part Warranty E - Billing Error			
		<input type="checkbox"/> C - Ordered Incorrectly F - Request Return			
Magnum Customer ID: _____		Date of claim: _____			
Company: _____		Customer reference #: _____			
Address: _____		Customer: _____			
		Address: _____			
Phone: _____					
Fax: _____		Phone: _____			
Warranty Contact: _____		Fax: _____			
E-mail: _____					
Unit Model #: _____		In service date: _____			
Unit Serial #: _____		Failure date: _____			
		Unit Hour: _____			
Qty	Part #	Part Description	SO # or Invoice #	Price (U.S. \$)	Labor hrs (rate \$60/hr)
The amount paid for a part purchased at an outside vendor will be reimbursed at Magnum Products LLC's discretion. List Complaint, Cause, Correction in Detail with technical data for claim consideration					
Warranty coverage is based on manufactures warranty					
For Magnum Products LLC use only					
		Date claim received: _____		Claim #: _____	
Return parts to Magnum <input type="checkbox"/>		RGA #: _____			
Scrap parts at customer <input type="checkbox"/>		Date parts returned: _____			
Claim approved <input type="checkbox"/>		Claim rejected <input type="checkbox"/>		Date _____	
Notes: _____					
				Acct #: _____	
Date: _____		Initial: _____		Amount: _____	
<small>Magnum Products LLC 215 Power Drive Berlin, WI 54923-2420 Ph: 800-926-9768 Fax: 920-361-2214 E-mail: warranty@m-p-llc.com The MAGNUM Claim Policy Manual is located in the service section of our website at: www.m-p-llc.com</small>					

Continued on next page



Claim Form, Continued

Submitting Claims

Once claim forms have been completed they can be sent to Magnum Products LLC by mail, fax or e-mail:

Mail	Fax	e-mail
Magnum Products LLC 215 Power Drive Berlin, WI 54923-2420	(920) 361-2214	warranty@m-p-llc.com

Claim requests will be returned to the buyer if incorrect or insufficient information is received.

Claim forms must not be held for more than 60 days before submitting them to Magnum Products LLC.
